



MONTANA DEPARTMENT OF ENVIRONMENTAL QUALITY

STORM WATER MANAGEMENT DURING CONSTRUCTION FIELD GUIDE FOR BEST MANAGEMENT PRACTICES



ACRONYMS

ACE – Army Corps of Engineers
BMP – Best Management Practice
CWA - Clean Water Act
DEQ - Montana Department of Environmental Quality
ELG - Effluent Limitation Guidelines
EPA - Environmental Protection Agency
MDT - Montana Department of Transportation
MPDES - Montana Pollution Discharge Elimination System
MS4 - Municipal Separate Storm Sewer System
NOI – Notice of Intent
NOT – Notice of Termination
NOV – Notice of Violation
NPDES - National Pollutant Discharge Elimination System
SWPPP - Stormwater Pollution Prevention Plan
WPB – Water Protection Bureau, within the Montana Department of Environmental Quality

PURPOSE OF THIS FIELD GUIDE

This MTDEQ BMP Field Guide has been designed and developed for use by storm water management professionals in the field during construction. This Field Guide includes:

- Construction Storm Water Permit information
- Storm water management fundamentals
- Erosion and sediment control practices
- Installation details for a wide range of Best Management Practices (BMPs)
- Photographic examples of correct and incorrect installations of BMPs
- Contact information

STORM WATER REGULATORY BACKGROUND

The Montana Department of Environmental Quality (DEQ) administers the Montana Pollutant Discharge Elimination System (MPDES) Permit Program through the Montana Water Quality Act. The goal of the MPDES Permit Program is to control point source discharges of wastewater, process water and storm water, so water quality in state surface water is protected. The MPDES Permit Program is delegated to the State of Montana through the Clean Water Act and the United States Environmental Protection Agency. Tribal lands and federally funded projects on federal lands remain under the National Pollutant Discharge Elimination System (NPDES).

Construction activities that result in the “disturbance” of equal to or greater than one acre of total land area are required to obtain permit coverage under the General Permit for Storm Water Discharges Associated with Construction Activity (Construction General Permit). (Activities deemed to be maintenance, with less than 5-acres of disturbance are not included.) Additional construction activities requiring permit coverage include the disturbance of less than one acre of total land area that is part of a “larger common plan of development or sale” if the larger common plan will ultimately disturb one acre or more. “Disturbance” related to construction activities is defined as any area that is subject to clearing, excavating, grading, stockpiling earth materials, and placement/removal of earth material.

The permittee is typically the construction project owner, primary earthwork contractor, or general contractor for the project, although it could be another party.

WHAT IS THE CONCERN WITH STORM WATER RUN-OFF FROM CONSTRUCTION ACTIVITIES?

Storm water runoff is generated when precipitation from rain and snowmelt events flows over land or impervious surfaces and does not percolate into the ground. Storm water runoff from construction activities can have a significant impact on water quality, because it may carry pollutants from the construction site directly to a storm sewer system or a state water body.

Sediment runoff rates from construction sites are 10 to 20 times greater than those from agricultural lands, and 1,000 to 2,000 times greater than those of forestlands. During a short period of time, construction activity can contribute more sediment to streams than is naturally deposited over several decades.

THE FUNDAMENTALS OF STORM WATER MANAGEMENT DURING CONSTRUCTION

Individuals seeking permit coverage under the Construction General Permit are required to develop, implement, and maintain a Storm Water Pollution Prevention Plan (SWPPP). The purpose of the SWPPP is to identify potential sources of pollutants and select Best Management Practices (BMPs) to minimize or eliminate the potential for these pollutants to reach state surface waters in storm water runoff. *BMPs can be: schedules of activities, prohibitions of practices, maintenance procedures, and other management practices to prevent or reduce the pollution of waters of the State. BMPs also include treatment requirements, operating procedures, pollution prevention, and practices to control site runoff, spillage or leaks, waste disposal, or drainage from material storage.* State waters are defined as any waters on the earth's surface including

but not limited to, streams, lakes, ponds, and reservoirs, and irrigation and drainage systems discharging directly into a stream, lake, pond, reservoir, or other surface water.

After assessing site characteristics and how storm water run-off may impact the construction site, the permittee should identify all potential pollutant sources, such as sediment from disturbed areas, stored wastes and fuels. BMPs, which will function to minimize or eliminate the potential for these pollutants to reach surface waters through storm water runoff, should then be selected and implemented. These BMPs are then detailed in the site specific SWPPP, which provides a written (through the narrative) and visual (through the detail drawings and site map) strategy for successful pollution control and storm water management.

BMPs at construction sites should consist of various erosion and sediment control measures for exposed soils, as well as materials handling and waste management measures. These practices and control measures are either installed (physical or structural in nature) or implemented (procedural or activity driven). It is the responsibility of the permittee to verify potential BMP restrictions with other regulatory agencies (e.g., US Army Corps of Engineers, municipalities).

Erosion and sediment control for areas of disturbance and controls for materials and waste are best accomplished with the proper selection, installation, evaluation and maintenance of appropriate control features.

All control features require routine inspections and maintenance to ensure continuous, effective operation. Periodic site inspections by qualified

personnel (such as the SWPPP Administrator) are required under the Construction General Permit and should focus on effective management of pollutants and preventive maintenance of BMPs. BMPs should be monitored for function, with any accumulated sediments removed frequently.

Impacts on exposed soils from storm water runoff can generally be separated into two distinct categories; surface erosion and sedimentation, and there are different BMPs to manage them.

Erosion Control is preferred over *Sediment Control*, as *Erosion Control* is a preventive measure, focusing on the cause of sedimentation. *Sediment Controls* are considered secondary BMPs, because they are responsive as opposed to preventive. They come into play after the damage from erosion has already impacted the site.

Erosion Control

Erosion control BMPs usually consist of a ground cover BMP used to prevent any of the forms of erosion from occurring. Emphasis should be placed on controlling erosion through preventative practices and control measures, which include: planning, project phasing, vegetative cover, and grading controls.

Sediment Control

Sediment control BMPs are designed to prevent soil particles already being carried in storm water from discharging from the construction site. Sediment control BMPs are not as effective as erosion control BMPs and are typically considered secondary practices installed after all opportunities for erosion control have been implemented. Examples of sediment control BMPs include: inlet protection, silt fence, straw

wattles, sediment traps, and other perimeter control devices.

HOUSEKEEPING PRACTICES

Additional pollutant sources associated with construction projects include the following sources: materials handling/management and waste management practices.

Materials Handling includes the storage and use of construction materials. These areas include fueling operations, equipment staging areas, maintenance areas, concrete or asphalt batch plants, and material borrow areas.

Waste Management includes worker trash, portable sanitary facilities, demolition materials, remnants from construction, and sawing/cutting operations.

Petroleum Products, Fertilizers, Herbicides, and Building Materials that are stored and used on construction project sites can contribute hydrocarbons, metals, and other toxic substances in runoff.

Concrete Washout in liquid form contains particles and is highly alkaline. High pH values are toxic to aquatic organisms.

ADDITIONAL DEQ PERMIT INFORMATION

Construction Dewatering General Permit authorizes the discharge of water from cofferdams, trenches, excavation pits or other excavations associated with construction where sediment-laden groundwater or surface water inflow must be discharged to state surface water. This permit also applies to sediment laden water from well pump tests, well development, drill hole or pylon development when the discharged water

may contain visible suspended and bed load sediment that must be settled prior to discharge.

318 Authorizations: authorizes a short term exceedence of a water quality standard for turbidity.

Sand and Gravel General Permit authorizes the discharge of wash water, transport water, scrubber water, and pit dewatering water or other process water to state waters.

Petroleum Clean Up General Permit authorizes the discharge of petroleum-related, contaminated water treatment facilities to state waters.

MDT STANDARDS

The information depicted in this manual may differ from the information included in MDT's Detailed Drawings. No information depicted in this manual supersedes MDT's contractual terms and conditions. In the event of a conflict between this manual and MDT's contract, the contractual language takes precedence.

ACKNOWLEDGEMENTS

The Montana Department of Environmental Quality would like to acknowledge: the Montana Department of Transportation, Montana Contractor's Association and Altitude Training Associates for making this BMP Field Guide possible. All BMP photography and the Inlet Protection detail drawings by Tom Gore, Altitude Training Associates.

TABLE OF CONTENTS

EROSION CONTROL BMPs

GRADING TECHNIQUES	1
Surface Roughening	2
Diversion Ditches	6
Slope Drains	9
Velocity Checks (Check Dams)	12
Preserving Natural Vegetation & Vegetative Buffers	15

SEDIMENT CONTROL BMPs

PERIMETER CONTROL AND BARRIERS

Silt Fence	18
Straw Wattles	22
Earthen Berms	25
Inlet Protection	27
Sediment Traps	34
Sediment Basins	37

VEHICLE TRACK PADS 39

ROADWAY MANAGEMENT 42

STABILIZATION BMPs

Seeding	46
Erosion Control Blankets	48
Straw Mulch	51

MATERIALS HANDLING, EQUIPMENT

MANAGEMENT 53

Bulk Storage	54
Equipment Management	55
Spill Prevention and Response	57

WASTE MANAGEMENT

Refuse and Trash	58
Concrete Washout Areas	59
Saw Cutting	61
Portable Toilets	62

CONTACT INFORMATION Back Cover

EROSION CONTROL BMPs

GRADING TECHNIQUES

Controlling the amount of disturbed area and the amount of time these areas will remain open, is a valuable planning tool referred to as *Phasing*. *Phasing* the grading operations during construction is a specific erosion control strategy, achieved by managing the sequencing of the work. Clearing and grubbing only the areas that are on a schedule for completion, is an important planning BMP. Implementing this procedural BMP greatly reduces the costs associated with installing BMPs.

Other grading control BMPs are designed to focus on managing site drainage. Determining and controlling potential run-on points, along with controlling how run-off will convey through (or around) a construction site is fundamental to storm water management on construction sites. Contractors that are tuned into storm water management on their construction sites will routinely assess how precipitation events will impact their sites.



SURFACE ROUGHENING

Disturbed areas that have become hard packed from vehicular traffic are not very conducive to absorbing run-off. As a result, this ponded precipitation is conveyed downgradient and can cause scouring and erosion in the process.

Surface Roughening, implemented as a grading control, breaks up the ground and makes it more receptive to absorption. By mechanically ripping, diking, tracking, or scarifying the ground, the surface area is increased and the absorption of run-off is facilitated.

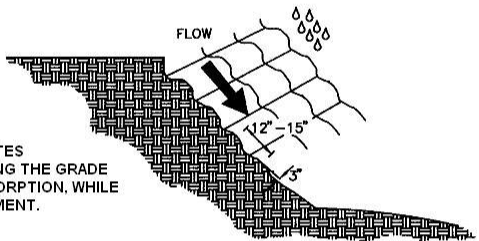
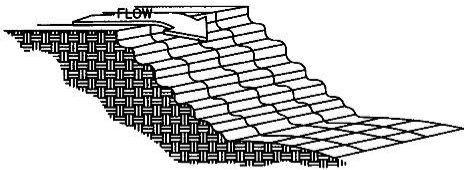

SURFACE ROUGHENING CREATES BENCHES AND FURROWS ALONG THE GRADE CONTOURS, PROMOTING ABSORPTION, WHILE TRAPPING RUN-OFF AND SEDIMENT.

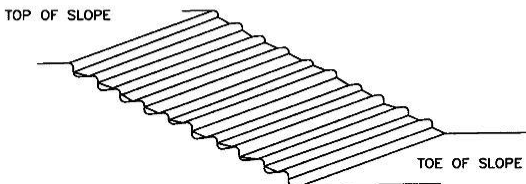

Adapted from the City of Farmington, NM SWPPP

If installed correctly, *Surface Roughening* will create furrows and small terraces that can slow down flows, promote infiltration and capture sediment.

SURFACE ROUGHENING (Con.)

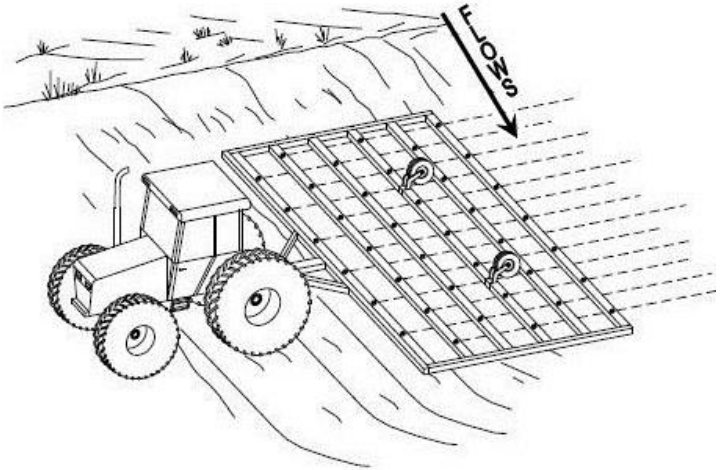

Adapted from Montana Department of Transportation
208 Standards



Many, varying mechanical methods may be used to achieve *Surface Roughening*. The degree or aggressiveness of the technique implemented should correspond to the steepness of the grade and soil type.

SURFACE ROUGHENING (Con.)



Grooves or furrows created by *Surface Roughening* should follow along the contours of the grade, as noted in this example.



Inappropriate grading techniques will leave cutting running up and down the vertical plane, which facilitates channeling and erosion.

SURFACE ROUGHENING (Con.)

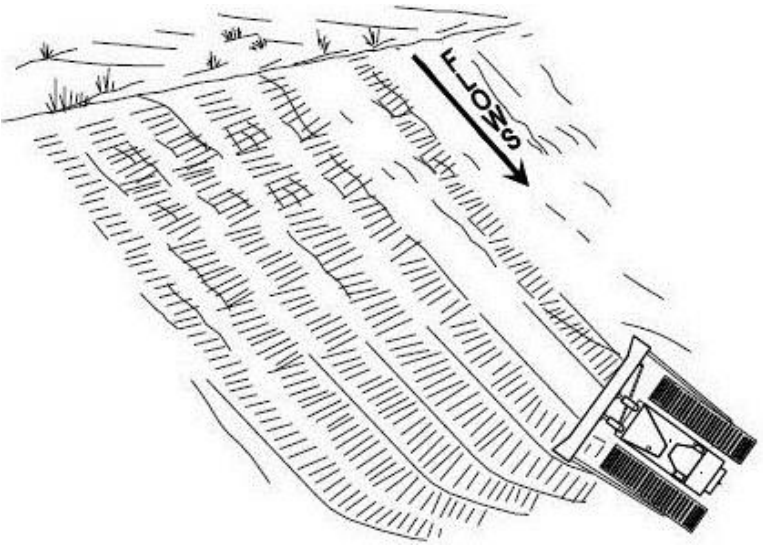

Adapted from Montana Department of Transportation
208 Standards



A lower profile dozer tracking technique may function well on shallower slopes. The ridges created by the equipment follow along the grade contours.

EROSION CONTROL BMPs (con.)

DIVERSION DITCHES

Diversion Ditches can be cut in to capture run-on and divert flows around a project or control site drainage by directing flows away from areas of disturbance and into detention facilities. They function as temporary conveyances, to direct run-off to a desired location.

When diversions are constructed, they should have rounded or flat bottoms to avoid concentrating the flows at the bottom of the channel, which can lead to ditch cutting. Installation should also ensure positive drainage and include a well-defined destination, such as a sediment trap or expansive vegetated area.

Inspections for diversions should verify they conform to the original installation detail and can continue to function as intended. Periodic regrooming may be required to restore definition and function.

Diversion Ditches may be constructed in conjunction with an *Earthen Berm*. The addition of a compacted *Earthen Berm* will increase the capacity of the ditch and prevent the feature from being overwhelmed or by-passed.

Diversions installed during construction may transition to permanent, post-construction drainage swales. In this scenario, it may be advantageous to work the feature to completion, i.e. grass lined swale, rip rap run down, concrete pan, etc. By working the feature to its final disposition, the contractor will avoid implementing transitional BMPs and the costs associated with their maintenance.

DIVERSION DITCHES (con.)

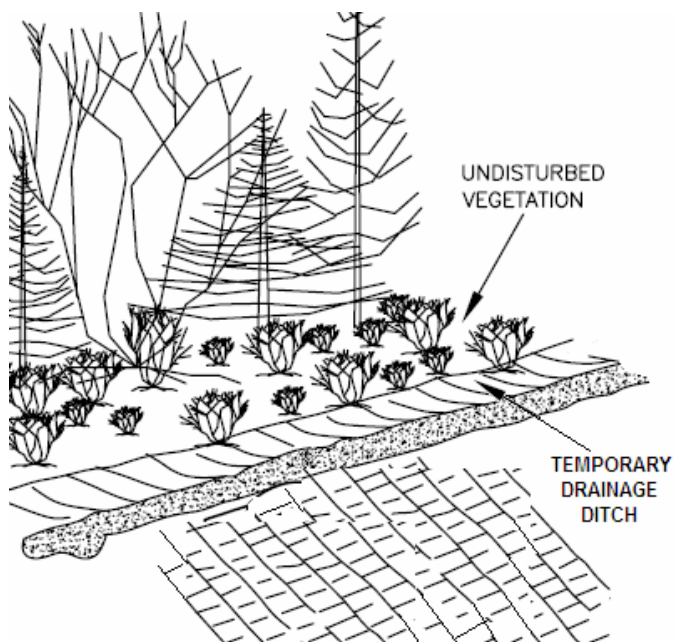

Adapted from CleanWater Services

Diversion Ditch used to intercept run-on,
above a graded slope.

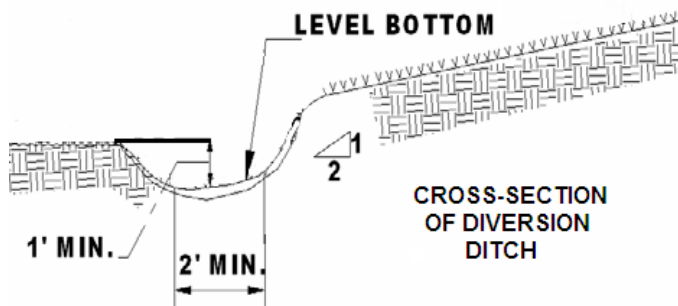

Adapted from Louisville MSD

DIVERSION DITCHES (con.)



A well-constructed *Diversion Ditch* will convey flows within the feature without erosion and degradation.



Diversions should not include loose fill.

SLOPE DRAINS

Managing site drainage on construction sites that have steep grades can be challenging. With no controls in place, gravitational forces will concentrate run-off down these embankments, resulting in gully erosion. Subsequent storm events will quickly elevate the surface erosion to property damage.

Installing temporary *Slope Drains* (also referred to as Embankment Protectors) allows the contractor to determine where and how run-off will be conveyed down a grade. The *Slope Drain* is often a pipe, which functions as a conduit for storm water, to prevent erosion on the slope, whether the grade consists of exposed soils, is newly seeded or is blanketed.

Slope Drains are typically installed in conjunction with other drainage features, such as ditches, to direct the run-off to the pipe. This can help to complete the process of keeping run-off away from work areas and focusing it where the contractor wants it to drain.

Installation for *Slope Drains* will include outfall protection to prevent scour, as there will be a concentrated flow with the point source discharge at the end of the feature. Outfall protection can be rip rap or a rolled erosion control product. If piping is used for the *Slope Drain*, the sections need to be tightly adjoined and adequately secured to prevent by-pass or dislodging.

Inspections for *Slope Drains* should ensure on-going function. Maintenance should be initiated if; piping is not secured in place, flows are bypassing the feature, there is erosion or sediment deposition at the outfall or in the piping.

SLOPE DRAINS (con.)

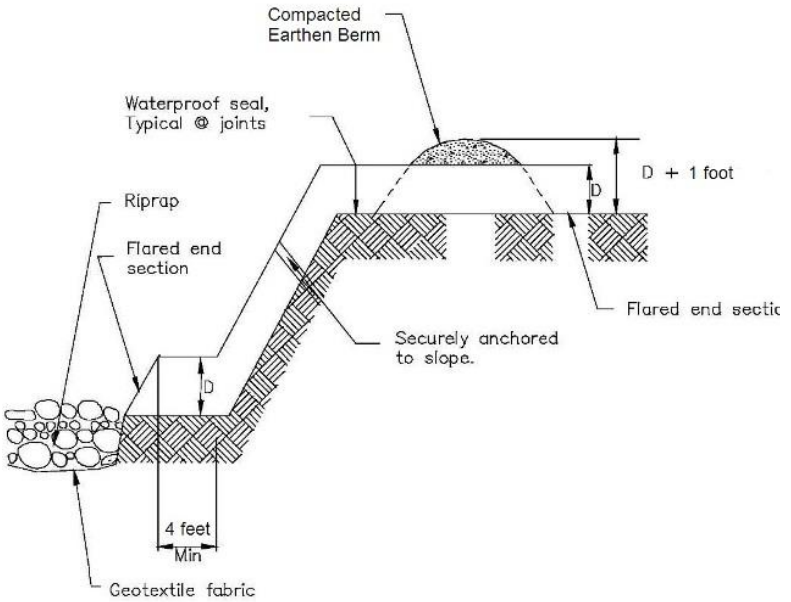

Adapted from CalTrans Div of Construction

***Slope Drain* installation for safely conveying run-off down a grade without impacting the slope.**

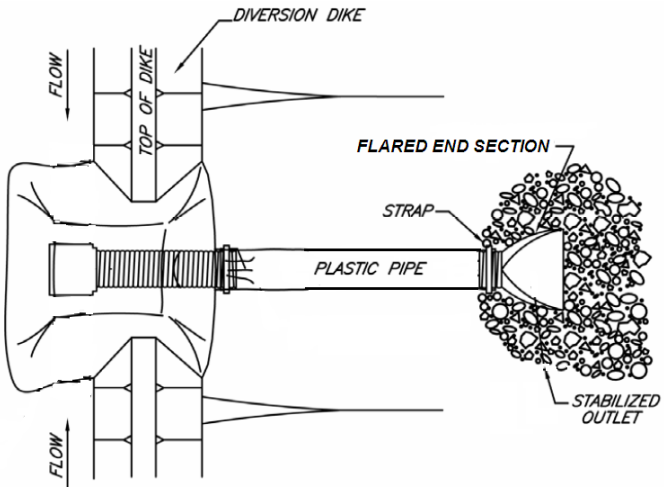

Adapted from Portland, OR Erosion Control Manual

SLOPE DRAINS (con.)



***Slope Drains* can function effectively for conveying flows down an unstabilized grade.**



Adequate outfall protection is required at the termination point to prevent scouring.

EROSION CONTROL BMPs (con.)

VELOCITY CHECKS (CHECK DAMS)

Ditches, channels and swales used to convey stormwater run-off can be impacted by erosive flows. Flows that are allowed to run unchecked in these features can rapidly erode the feature. If these features are not stabilized with a liner, or vegetation, *Velocity Checks* can be installed to provide erosion control on a temporary basis.

The function of the *Velocity Check* in a storm water conveyance is to slow the flow and prevent erosion. This is accomplished by breaking up the erosive velocity of the flow, allowing the flows to pass through or over the feature at a slower rate. The contour of the conveyance is equally important. As noted in the section on *Diversion Ditches*, the ditch bottom should be flat or rounded to promote a thinner layered or more laminar flow.

Many styles of *Velocity Checks* (constructed or prefabricated) can perform adequately. *Silt Fencing*, and other BMPs that do not function in concentrated flows, cannot perform as *Velocity Checks*. Features that have a tendency to pond large volumes of run-off should also be avoided.

Installation of *Velocity Checks* will include burying the feature below grade (to prevent undermining), appropriate spacing (to prevent the flows from regaining erosive velocity) and keying into the adjoining grade/embankment (to prevent bypass around the ends).

Inspections should verify the features can continue to function. Maintenance practices should be initiated if performance has been impacted by sediment or debris, and if the feature has been bypassed or damaged.

VELOCITY CHECKS (CHECK DAMS) (con.)

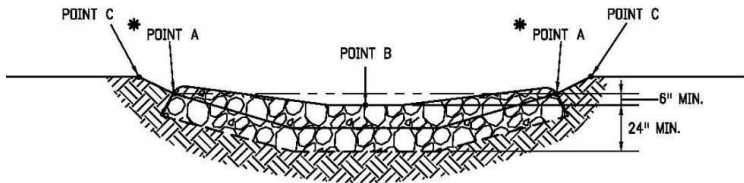

* POINTS "A" SHALL BE HIGHER THAN POINT "B" AND BELOW POINTS "C".

TYPICAL SECTION VIEW

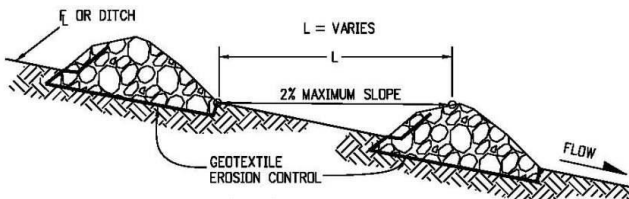

SECTION VIEW ALONG DITCH FLOWLINE

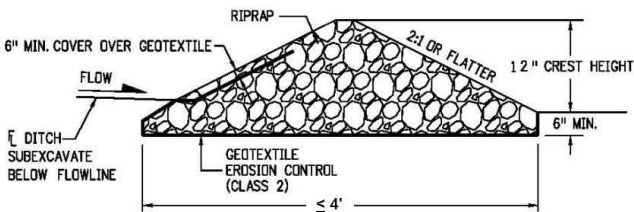

SECTION DETAIL

NOTES:

1. RIPRAP SIZE $D_{50} = 6"$ OR AS SHOWN ON THE PLANS.
2. THE ENDS OF RIPRAP CHECK DAM SHALL BE A MINIMUM OF 6 IN. HIGHER THAN CENTER OF CHECK DAM.

ROCK CHECK DAM

Adapted from Colorado DOT M-Standards

Rock Velocity Checks will intercept and slow flows in ditches and swales, preventing ditch cutting and scour. **Velocity Checks** are not recommended for larger drainage areas or steep grades.

VELOCITY CHECKS (CHECK DAMS) (con.)



Correctly installed rock *Velocity Checks* will allow flows through and over the feature without bypass or undermining.



Straw Bales do not perform well as *Velocity Checks*. Flows do not penetrate the bales, which creates ponding and hydraulic pressure. This pressure will consistently force the water under the bales, creating erosion from the undermining.

PRESERVING NATURAL VEGETATION & VEGETATIVE BUFFERS

The potential for surface erosion is accelerated when vegetative cover is removed; hence a key goal of storm water management during construction entails using vegetation as a BMP. Recognizing this, contractors know planning to preserve vegetation in place can be a powerful, natural erosion control tool at their disposal. At a minimum the vegetation protects the ground from raindrop impact while the root system helps hold the soils in place. Preserving natural vegetation in place as a BMP is referred to as a *Vegetative Buffer Strip*.

Vegetative Buffer Strips along perimeters and other downgradient areas will enhance erosion control efforts by reducing the velocity of run-on from upgradient areas. This decrease in run-on velocity will promote sheet flows (which are less erosive) and infiltration into the vegetated area, thus reducing run-off to down gradient areas or the site perimeter.

Advance planning for establishing *Vegetative Buffer Strips* will note the sizing and location of the buffer and should take into account the:

- Drainage area impacting the buffer strip
- Soil types
- Slope grade and length
- Type and density of vegetation
- Protection of the vegetated area

When designing a specific *Vegetative Buffer Strip*, the feature should have a minimum width of 25 feet. The 25 ft. width is functional for contributing areas of drainage approximating 125 feet upgradient of the vegetated area. An additional 1 ft. of width of vegetation should be included for each 5 ft. of additional upgradient area of drainage.

PRESERVING NATURAL VEGETATION & VEGETATIVE BUFFERS (con.)



Any areas where natural vegetation can be maintained in place will be greatly beneficial for erosion control. Preserving existing vegetation for even short periods will reduce areas of disturbance requiring controls.

Although some sediment removal on any preserved vegetation can be anticipated, it can also be easily overwhelmed with sediment plumes, if relied on too heavily as a sediment removal BMP. Inspections should verify sediment accumulations have not started to pave over the vegetated area, impacting its growth.

Limitations for *Vegetative Buffers* include:

- Ensuring run-on to vegetated area is sheet flow
- Limiting the area contributing run-on to ½-acre in size
- Having a vegetated area comprised of dense vegetation (typically defined as grassy cover 3" in height, with a density of 90% cover)
- Ensuring the slope of upgradient area and of the vegetated area do not exceed 6% grade.

PRESERVING NATURAL VEGETATION & VEGETATIVE BUFFERS (con.)

Areas of preserved vegetation can be prone to damage if they take on concentrated flows from upgradient drainage areas. There are a few installation techniques that can help convert those run-on concentrated flows into sheet flows.

Various styles of *Level Spreaders* can intercept concentrated run-on upgradient of the vegetated area. The goal of the Level Spreader is to slow down the run-on and disperse it over a wider area. Similar to the function of a *Velocity Check* (Check Dam), a *Rock Berm* running the width of the vegetated area can help to diffuse concentrated run-on. Another, more effective, application is an *Interceptor Trench* at the top of the vegetated area. The concentrated run-on is caught in a gravel filled trench, then dispersed across the length of the trench, discharging onto the vegetated area as sheet flow.

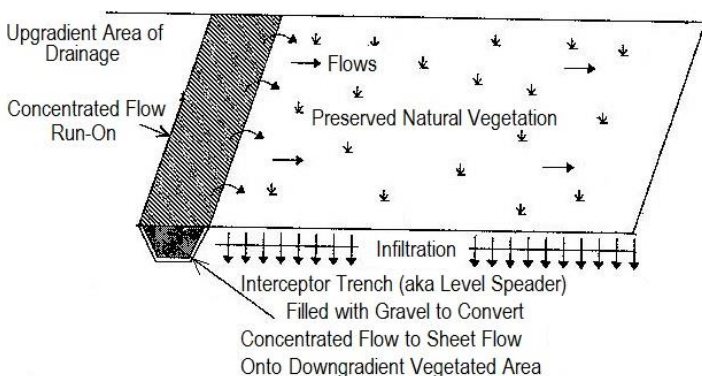

Adapted from California Stormwater BMP Handbook

Example of an *Interceptor Trench* installed between an area of disturbance to the left and the *Vegetated Buffer* on the right.

Concentrated run-on, captured in the trench, is discharged as sheet flow.

SEDIMENT CONTROL BMPs

SILT FENCE

Sediment controls are secondary BMPs pursued after erosion control practices have been maximized. Therefore, *Silt Fencing* should be implemented after all other opportunities for erosion control have been exhausted.

Silt Fencing performs as a barrier, intercepting runoff and impounding it. The fabric promotes ponding because very little run-off discharges through the material. Silt fencings ability to weep is further diminished if the material becomes clogged with sediment accumulations

Silt Fencing has many limitations that must be carefully evaluated prior to installation. Understanding these limitations will help to determine if it is the appropriate BMP for the site conditions and ensure that it can be sited correctly for maximum performance.

Silt Fencing cannot:

- Function in concentrated flow
- Manage large drainage areas alone
- Perform if not installed along the grade contour
- Work well installed right at the toe of a slope

Silt Fence functions in limited drainage areas, typically no more than $\frac{1}{4}$ acre of disturbance discharging to 100 linear ft. of fencing (if *Silt Fencing* is the only BMP implemented to manage the area).

Maintenance should be triggered if sediment accumulations impact its ability to function. Also, if the fabric is not: taut, intact, secured to the stakes, trenched in, adjoined correctly, or if stakes are not upright or are broken.

SILT FENCE (con.)

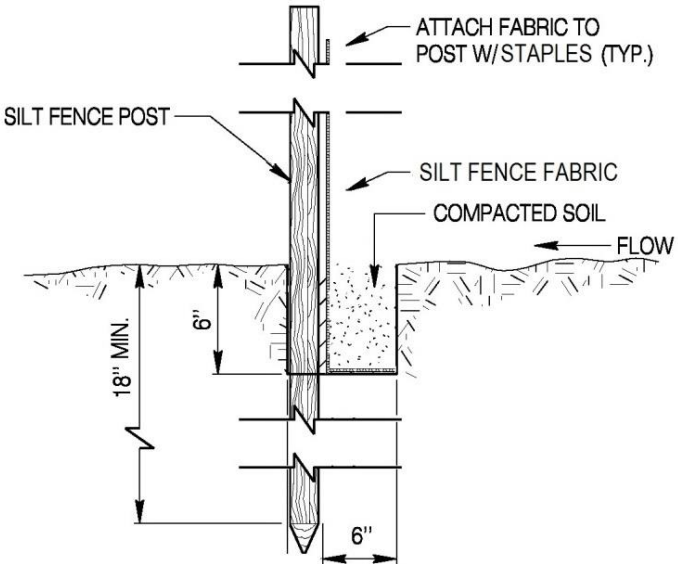
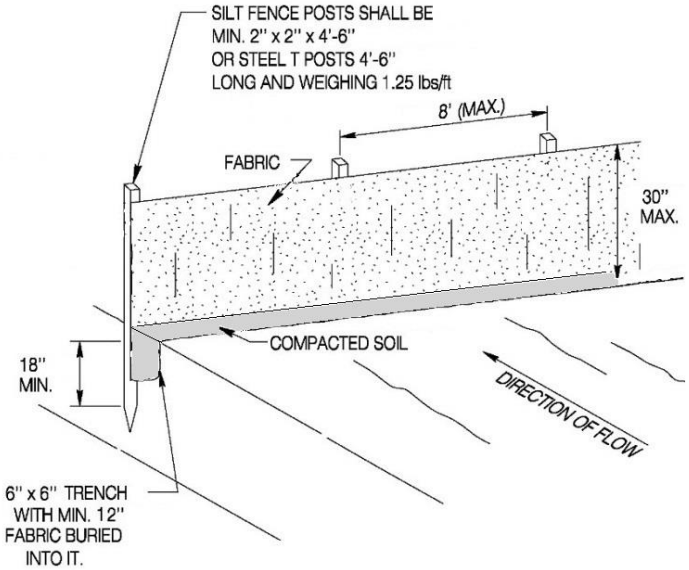

Adapted from WYDOT Temp. Erosion Control Measures

Silt Fencing must be installed correctly (according to the selected detail) in order to function as intended.

SILT FENCE (con.)



If sited and installed correctly, *Silt Fence* can perform well as a sediment barrier and to pond storm water.



Silt Fence is not designed to divert run-off and cannot function if it is installed running up and down a grade.

SILT FENCE (con.)



Silt Fence functions best when backed away from the toe of a slope. Note the buffer zone of ***Surface Roughening*** here.



Silt Fence is not designed to work in a concentrated flow. Adding additional rows will not alter that design standard.

STRAW WATTLES

Straw Wattles can function as a sediment barrier/perimeter control BMP for small drainage areas. Like *Silt Fencing*, the drainage area should be limited to ¼-acre of disturbance per 100 linear ft. A common misconception with wattles is they filter run-off. During manufacture, the wattles are routinely packed so tight that they do not promote flows penetrating the material. Consequently, their function is restricted to ponding run-off and overtopping.

The low profile of the *Straw Wattle* installation places limitations on the field applications for the feature. The most appropriate applications for *Straw Wattles* that will allow them to function are:

- Smaller drainage areas with sheet flows
- Areas with flatter grades
- In conjunction with other BMPs, preferably erosion control

Installation details for *Straw Wattles* will consistently include:

- Wattle diameter
- Installation along the drainage contour
- Trenching below grade and backfilled
- Firmly secured down
- Hooked up at the ends
- Adequately overlapped at joints

A frequent failure point is undermining. This is minimized with trenching the wattle below grade, backfilling and compacting on the upgradient side.

Inspections should verify the wattles remain intact, secure and functioning. Maintenance should be initiated if the wattles no longer match the installation detail, the wattles are flattened or damaged, impacted with sediment, stakes are loose, broken or the wattles aren't secured down.

STRAW WATTLES (con.)

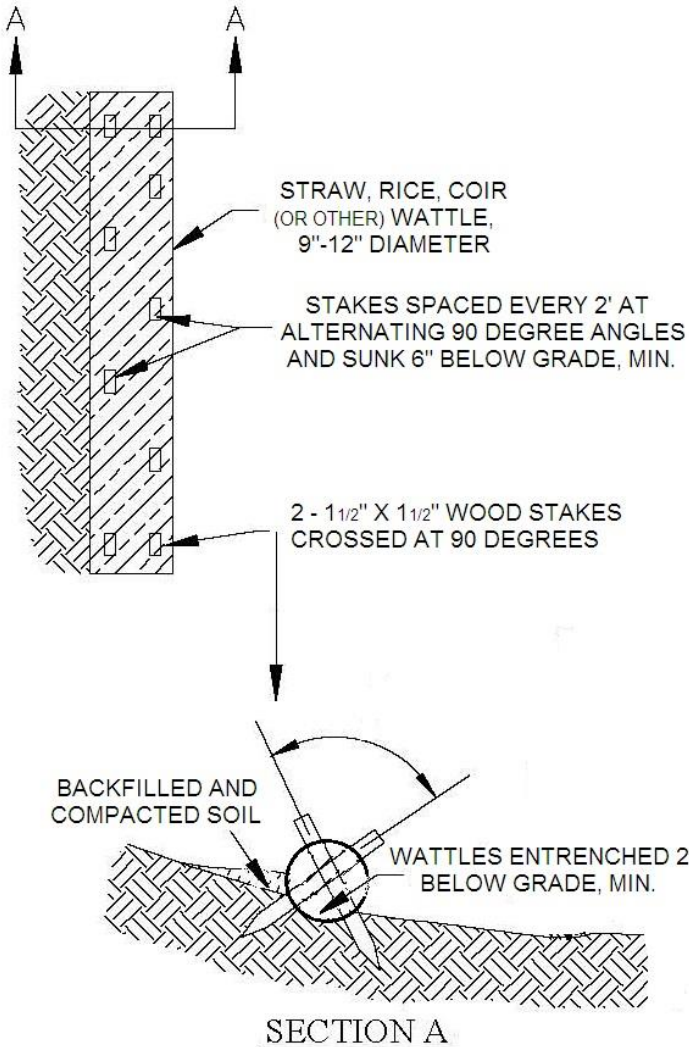

Adapted from City of Arvada, CO Erosion Control Details

Straw Wattles must be installed correctly to ensure proper function, prevent by-pass and reduce maintenance costs.

STRAW WATTLES (con.)



Good example of *Straw Wattles* installed as perimeter control/sediment barriers for small area of disturbance with no run-on.



Straw Wattles need to be adequately secured down. The stakes for this installation were driven along the sides, instead of through the wattles.

EARTHEN BERM

Earthen Berms (also referred to as *Dikes*) are grading techniques that function as barriers for sediment control. Similar to *Silt Fencing*, *Earthen Berms* intercept and pond run-off. However, unlike *Silt Fencing*, which will weep, there is no such discharge from a berm. If an *Earthen Berm* discharges, it is typically not installed correctly. If the storm water discharges through or under the feature, it is not compacted correctly. If it discharges around the feature, it has not been turned up at the ends to prevent by-pass. If it discharges over the berm, the drainage area is too large or the height has not been correctly selected. If the feature overtops, it can be disastrous. Overtopping can lead to embankment failure and loss of impoundment.

Earthen Berms can be used in conjunction with ditches to divert flows. The installation of an *Earthen Berm* should ensure:

- Compaction of fill material, built in lifts
- Uniform height of berm
- It is on the grade contour and has turned up ends, to facilitate ponding

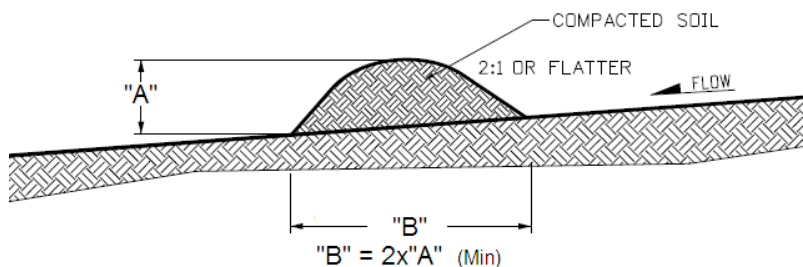

TEMPORARY BERM

NOTES:

1. BASE WIDTH WILL BE DETERMINED BY HEIGHT. HEIGHT WILL BE DETERMINED BY SIZE OF DRAINAGE AREA.
2. BERMS WILL FUNCTION TO INTERCEPT FLOWS AND IMPOUND THEM
3. BERMS WILL BE USED FOR LIMITED DRAINAGE AREAS, NOT TO EXCEED 1/4 ACRE FOR EVERY 100 LINEAR FEET OF BERM

Adapted from Colorado DOT M-Standards

EARTHEN BERM (con.)

Maintenance should address any damage to the integrity and function of the feature. Heavy sediment accumulations need to be addressed to restore ponding capacity.



Earthen Berms require compaction, to function as a viable barrier. A bladed windrow of loose fill can easily erode and does not provide a barrier with integrity.

INLET PROTECTION

Often referred to as the last line of defense, *Inlet Protection* is installed to prevent sediment-laden run-off from entering a storm drain inlet. The 'last line of defense' label relates to the frequent inability to implement treatment, once there has been a discharge to the box. Similar to other sediment control devices, *Inlet Protection* intercepts flows, but unlike most barriers, it is designed to discharge. Depending on the style implemented, *Inlet Protection* is designed to either filter or pond and overtop into the inlet.

Functioning as a sediment removal device, *Inlet Protection* does have limitations, and almost universally must be implemented in conjunction with other, upgradient BMPs in order to function. Different styles of inlets will require correspondingly different styles of *Inlet Protection*. These various inlet styles will include: curb-side inlet in a sump condition, on grade curb-side inlet or an area/drop style inlet in a green belt, landscaped area, or on a paved section.

Inlet Protection must be installed such that it can overtop. This is specifically important for curb-side inlets, so as to not create a public safety hazard with large ponding in the lane of traffic. For curb-side *Inlet Protection*, installation should also ensure a lengthy interface and marriage with the curb.

Inspections and maintenance activities should reinforce on-going, optimal function of the installation. Features that have become damaged, dislodged, impacted with sediment and/or debris must be addressed, to restore them to a fully functional condition. Features that have been overwhelmed with sediment will require additional, upgradient controls.

INLET PROTECTION (con.)

TYPICAL INLET PROTECTION INSTALLATION
FOR SUMP INLET LOCATIONS

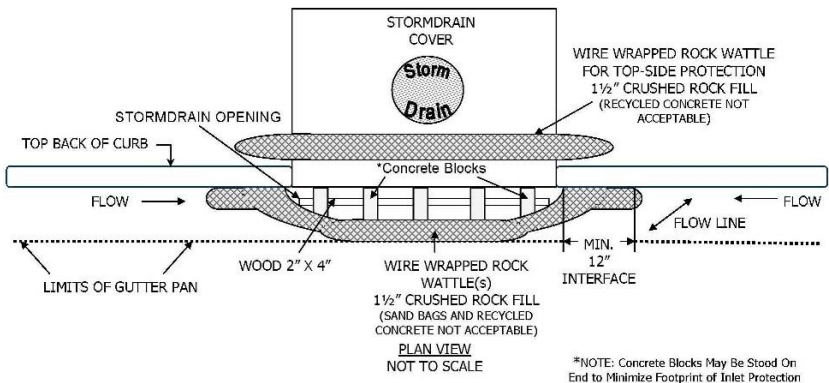

Typical 8" diameter wire-mesh wrapped rock wattle style *Inlet Protection* for curb-side inlets in a sump condition.



Good example of a sump-style *Inlet Protection* installation with one, long, continuous rock wattle. Note the long interface with the curb facing at each end.

INLET PROTECTION (con.)



Straw Wattles do not perform well as *Inlet Protection*. They do not filter flows and are prone to by-pass, because their light weight and buoyancy do not allow a good seal with the curb flowline.



***Inlet Protection* is not designed to hold back large sediment plumes. The rock wattles are easily clogged, overwhelmed and sediment is discharged to the box.**

INLET PROTECTION (con.)

TYPICAL INLET PROTECTION INSTALLATION FOR ON-GRADE INLET LOCATIONS

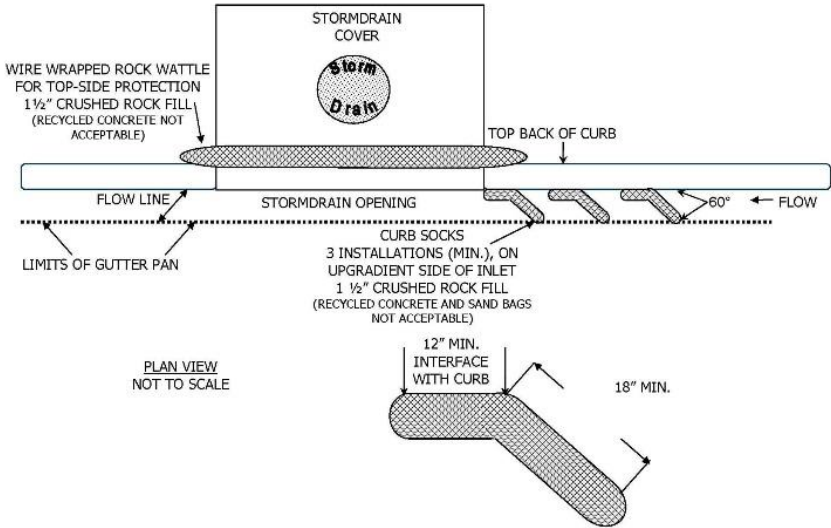

Curb Socks can assist with sediment removal in curb flowlines, prior to discharge to an inlet.

INLET PROTECTION (con.)



An appropriate style of curb sock must be selected to function as on-grade *Inlet Protection* to prevent by-pass.



Curb Socks cannot be allowed to become overwhelmed with sediment. These features can no longer function as BMPs and need to be replaced with other features.

INLET PROTECTION (con.)

TYPICAL INLET PROTECTION INSTALLATION FOR DROP/AREA INLET LOCATIONS

NOT TO SCALE

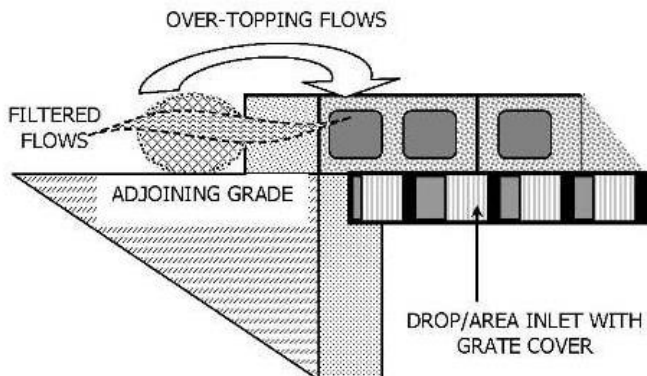

NOTE: ADDITIONAL LAYERS OF CONCRETE BLOCKS AND
ROCK WATTLES CAN BE ADDED, BASED ON ANTICIPATED
FLOWS.

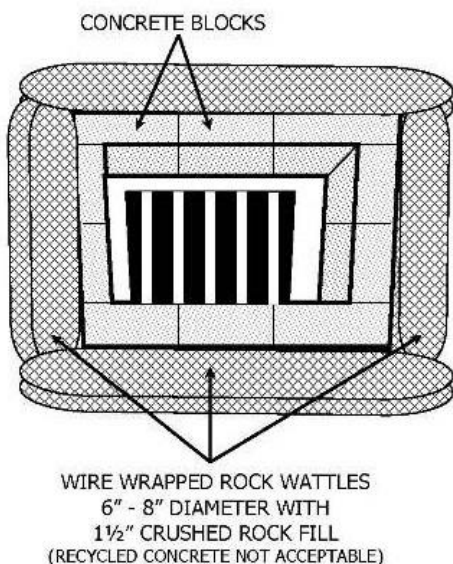

INLET PROTECTION (con.)



A gravel pack can be installed as a substitute to the wire mesh rock wattles for *Area Inlet Protection*, but may be more difficult to maintain or demolish.



***Inlet Protection* must be maintained in good operating condition and should not allow sediment to discharge to the box.**

SEDIMENT TRAPS

Sediment Traps can be used during construction to manage water quality as well as quantity, for small drainage areas. Functioning as sediment removal BMPs, traps will impound diverted flows and allow heavy particles to settle out. As entrapment facilities, traps can also help manage site drainage by providing temporary storage for run-on and run-off. Along with *Sediment Basins*, *Sediment Traps* are often the termination point for *Diversions Ditches*.

The installation of *Sediment Traps* will include design calculations for sizing, which is determined by drainage area. Presuming there will be sediment accumulations, dry and wet storage capacity must be included in these calculations. Installation will also include planning, to ensure the selected location of the feature will facilitate function and not interfere with site operations.

Planning considerations for the location of the feature must consider discharge means and location. The trap must be allowed to discharge at a designed, designated point and this discharge point should be sited so it will not impact the work. Ponding features without a means of discharge are vulnerable to embankment and ultimately pond failure. Berms for *Sediment Traps* will have a low point, or weir, constructed to facilitate a non-erosive discharge. The weir will include a layer of non-woven geotextile and rip-rap armoring, to prevent scour and damage to the berm, during discharge.

Inspections and maintenance will focus on the function of the feature. Has the integrity of the BMP been compromised? Can it continue to function as intended? Sediment accumulations should not impact function or storage capacity.

SEDIMENT TRAPS (con.)

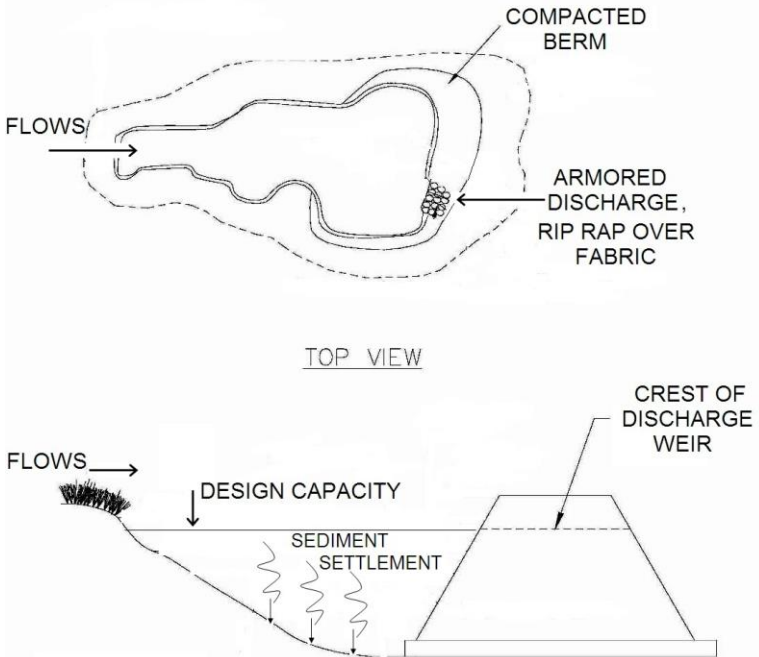

Adapted from CalTrans Division of Construction

Temporary *Sediment Trap* layout, with flows coming in one side and discharging out the other, over an armored outfall. Capacity is determined by the size of the drainage area discharging to the feature.



***Sediment Traps* can be sized to be effective BMPs for any style of construction.**

SEDIMENT TRAPS (con.)



Run-off accumulates at the low point of this *Sediment Trap*. The feature will discharge when the ponded volume reaches the low point of the armored weir.



Sediment Traps must be provided with a designed means of discharge. Note the eroded embankment here, which can lead to pond failure.

SEDIMENT BASINS

Sediment Basins, like *Sediment Traps*, are sized according to drainage area. *Sediment Basins* are designed larger for greater drainage areas. Aside from being larger, *Sediment Basins* have a perforated riser pipe as the primary discharge feature. Permanent ponds often function as *Sediment Basins* during construction, until they are fully commissioned as the long-term, storm water management BMPs they are designed for.

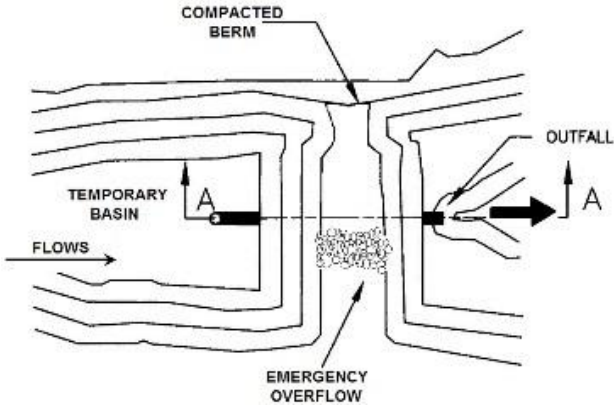

PLAN VIEW

NOT TO SCALE

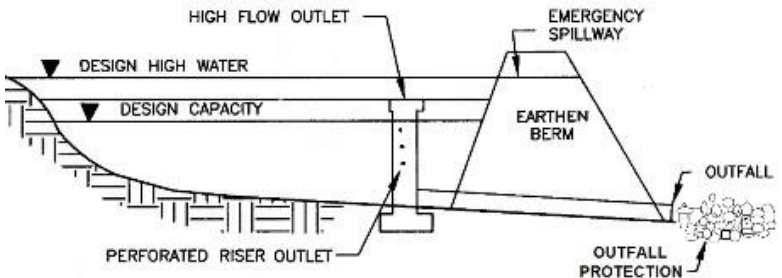

CROSS SECTION A

NOT TO SCALE

Adapted from City of Farmington, NM SWPPP

Temporary *Sediment Basins* will be constructed with a perforated riser pipe and emergency overflow for discharge.

SEDIMENT BASINS (con.)



Typical temporary *Sediment Basin*, with perforated riser pipe and armored overflow designated as the discharge points. Basins and Traps will be sized in relation to the drainage area conveying to the feature.



Inspections for potential maintenance need to evaluate for basin function, integrity of the installation and sediment accumulations.

VEHICLE TRACK PADS

Sediment tracking from vehicular traffic on construction sites can be a formidable challenge for contractors. Once sediment is tracked onto impervious surfaces, it is extremely difficult to manage and readily transported with run-off. Evaluating soil conditions, site access, traffic patterns, seasonal weather and appropriate BMP alternatives will all factor into implementing a successful vehicle tracking control program.

It is understood some sediment will be tracked onto paved sections during construction. And while street cleaning is a necessary procedural BMP, sediment tracking needs to be greatly minimized in order for it to be effective. A successful vehicle tracking program will include numerous administrative and structural BMPs to effectively minimize and control sediment tracking. These other BMPs can include; limiting site access, stabilized parking areas, project scheduling changes, halting work, wheel wash stations, subcontractor training and rumble strips.

Vehicle Track Pads can help with the reduction of sediment tracking onto paved sections from vehicular traffic transitioning from disturbed areas. They are not intended to remove all of the sediment off tires, but provide a stabilized ingress/ingress point and prevent rutting.

The installation of a *Vehicle Track Pad* will include an underlayment of non-woven geotextile and uniform placement of aggregate. The installation may need to include flared ends, to provide coverage for vehicles turn onto or off of the pad. Inspections will ensure the feature continues to match the installation detail and has not become impacted with sediment. Roadways need to be cleaned to prevent further track out.

VEHICLE TRACK PADS (con.)

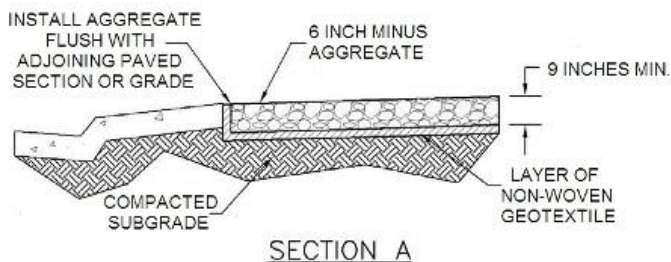
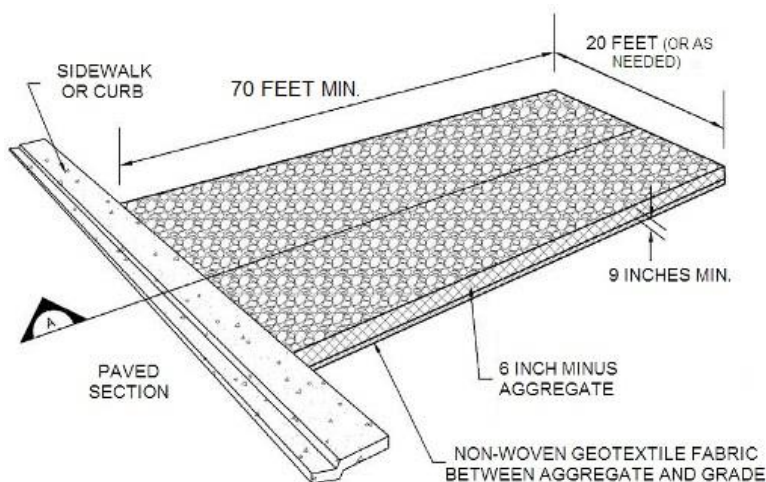

Adapted from UDFCD Criteria Manual, Vol. 3
Standard Vehicle Tracking Control Pad design. Installed feature will include an underlayment of fabric to prevent the aggregate from being pressed into the subgrade. A flared entrance may be included to facilitate the turning radius of traffic.

Track Pads will be regroomed, refreshed or replaced as needed to address sediment accumulations and to maintain a fully functional feature. Street cleaning activities will not include the use of water trucks or power washing, as they will generate sediment-laden discharges to the storm drain or off-site.

VEHICLE TRACK PADS (con.)



Cattle guards or rumble strips can be added to *Vehicle Track Pads* to aid with sediment removal from tires.



***Track Pads* by themselves will not control sediment tracking; other aggressive measures will typically be required.**

ROADWAY MANAGEMENT

Many construction and development projects rely heavily on roads for site access and traffic. For some activities these roads may transition to permanent, paved features. Regardless of their final disposition, roads need to function as traffic conveyances and storm water run-off conveyances during construction.

Planning is critical to assess the nature of site drainage. This has to be evaluated first. Before the BMP selection can be made for drainage control, a determination will need to be made as to how the roadway will drain,. There are many styles of roads and just like any other storm water BMP; the selection process should be approached in a calculated manner.

What are some of the considerations?

- How is the area draining now, and does that need to be modified?
- Is there run-on? Is it concentrated or sheet flow? How Much? When?
- Where is the run-off going?
- Is there evidence of erosion now?
- How long will the roadway be in place?
- Will the road be dirt or gravel?



ROADWAY MANAGEMENT (con.)

A re-occurring theme in storm water management: where's the water coming from? If there is run-on, coming onto areas of disturbance, it most likely will need to be addressed. Roads are no different; one of the goals should be to keep flows off of the road. It may not always be practical, or possible to address the upgradient source of run-on, but that is almost always the best first approach.

If it is possible to divert the flows away from areas of disturbance, or reduce them, you eliminate or minimize the concern. This can be managed with berms, diversions, slope drains and ponds reviewed in other sections of this Field Guide.

Remember, you are not responsible for the quality of run-on. So, when you capture this and divert it around or through your work zone, you do not need to treat it prior to discharge. This is assuming the run-on is not originating from your construction area and you do not allow it to engage any of your areas of disturbance or pollutants.

The only other approach for addressing run-on is to intercept the flows prior to discharge onto the road in a roadside ditch. Run-on is captured in the roadside ditch and then conveyed alongside the road. The new concern is the concentrated flow in the ditch, which can cause ditch cutting. See the section on *Velocity Checks* earlier in this Field Guide to manage this.

ROADWAY MANAGEMENT (con.)

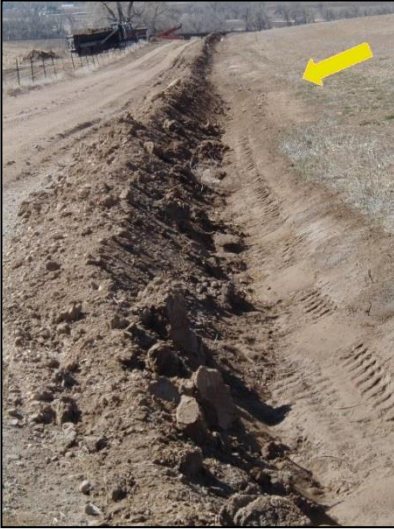

Run-on can be captured in a roadside ditch to prevent the flows from eroding the road. The concentrated flow in the ditch can cause erosion, which can be managed with *Velocity Checks*.

ROAD CONSTRUCTION

Once run-on conditions have been addressed for the road, the next issue is how the roadway itself will drain. Erosion concerns for the road surface can largely be addressed with rock or other aggregate paving.



Erosion control on roadways can be managed best with crushed aggregate material, to provide armoring.

ROAD CONSTRUCTION (con.)

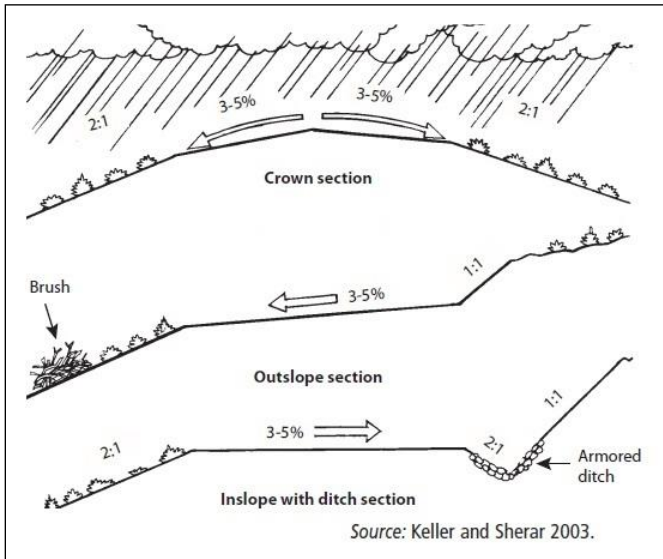

Conveying flows off of roadways is crucial to preventing erosion and preserving the integrity of the road surface. These three designs facilitate roadway drainage.

For all the styles of road construction detailed above, there will be a need for erosion control to manage the discharges of the flows off the roadway. Note the vegetation in the drawings for the adjoining areas. Obviously, without some form of stabilization (vegetation, rock, etc.) on this adjoining grade, the flows sheeting off the roadway can cause erosion. It is also important to keep these discharges in sheet flow whenever possible, because repetitive concentrated flow discharges will uproot vegetation and wash away rock.

STABILIZATION BMPs

SEEDING

Vegetative cover is regarded as the most powerful deterrent for surface erosion. Focusing on this aspect of erosion control, the strategy of quickly establishing vegetative growth on disturbed areas is a powerful planning BMP. Whether as a permanent measure for final stabilization or as temporary stabilization, a clear and steadfast focus should be given to *Seeding*.

Permanent Seeding

Permanent seeding should be implemented on areas of disturbance as soon as they are completed and available. It is not economical to wait until the end of the construction to implement seeding. More revenue can be expended installing and managing BMPs in completed areas, then implementing final stabilization.

Many factors will impact the planning and execution of *Seeding*. Important considerations:

- What is native to the region/elevation
- Soil type, preparation, grade and access
- Time of year, weather patterns
- Will area be irrigated
- Seed selection
- Application method
- Application rate
- Means of providing seedbed cover



Temporary Seeding

Areas that will be dormant or may not be fully readied for final stabilization may be candidates for *Temporary Seeding* applications. This technique can provide interim erosion control and control costs associated with repairing grades damaged by surface erosion.

EROSION SEEDING (MDT)



Adapted from Montana Department of Transportation
208 Standards

Erosion Seeding is the immediate seeding of freshly exposed slopes steeper than 3:1. Seeding is executed manually without mulch or fertilizer application, but stabilized with equipment tracking.



EROSION CONTROL BLANKETS

The function of *Erosion Control Blankets* is to provide cover and moisture for newly seeded areas. If some means of cover is not provided, seed beds will be vulnerable to wind and surface erosion. Moisture retention in the blankets will also promote germination.

Blankets are routinely selected for applications that require more resilient and longer term protection than may be expected from other, mechanically installed applications (such as straw or hydro-mulch).

A wide-range of styles, composition and thicknesses are available for the installer to choose from. In order to determine the correct grade of blanket, site conditions/characteristics must be evaluated. These include the “Five S’s”:

- Soil type
- Slope steepness and length
- Seed type, and number of years to yield established growth
- Season; projected precipitation or irrigated
- Sheet flow application, or concentrated flow

Correct installation will include; soil preparation, good soil contact, proper staking/pinning, overlapping, anchor slot, check slots or staple checks and correct orientation. Blankets that have become unsecured need to be addressed.

Blanket maintenance can be relatively minor, if the correct grade of blanket has been selected for the application and it is installed correctly. However, they still require routine inspections to verify that they demonstrate integrity, are intact and can continue to function until vegetative cover is established. Upgradient controls should prevent sediment deposition onto the blankets.

EROSION CONTROL BLANKETS (con.)

MATS / BLANKETS SHOULD
BE INSTALLED VERTICALLY
DOWN SLOPE

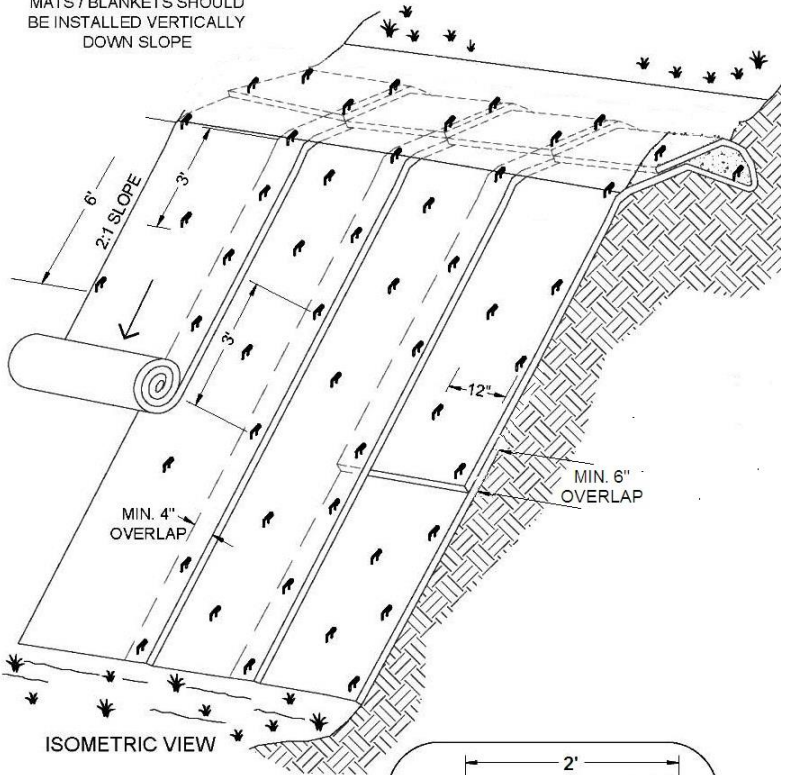

TYPICAL SLOPE
SOIL STABILIZATION

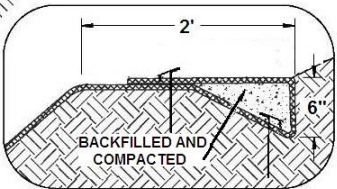

NOTES:

1. SLOPE SURFACE SHALL BE FREE OF ROCKS CLODS, STICKS AND GRASS. MATS / BLANKETS SHALL HAVE GOOD SOIL CONTACT.
2. APPLY PERMANENT SEEDING BEFORE PLACING BLANKETS.
3. LAY BLANKETS LOOSELY AND STAKE OR STAPLE TO MAINTAIN DIRECT CONTACT WITH THE SOIL. DO NOT STRETCH.

Adapted from Oklahoma City, OK SWQ Standards

***Erosion Control Blankets* must be installed running in the direction of the flow and adequately secured down. Good soil preparation, prior to placement, will prevent tenting or voids under the blanket.**

EROSION CONTROL BLANKETS (con.)



A good *Erosion Control Blanket* installation can provide long-term erosion control, seed-bed protection and promote germination.



Blanket installations need to be protected from damage due to site activities and traffic.

STRAW MULCH

A well crimped layer of *Straw Mulch* can function as an artificial root system, providing erosion control from wind and run-off. Applying *Straw Mulch* in conjunction with seeding provides a similar function as blankets, only not as robust or stable. The mulch will also protect the prepared grade from raindrop impact and then retain moisture to help germination. Crimped mulch can also be used alone, as a temporary stabilization (erosion control) technique in applications where disturbed areas are not ready to be seeded.

Straw Mulch performs best on flatter areas that receive sheet flows. Applications on slopes steeper than 4:1 and in concentrated flow scenarios (channels and drainage swales) must be avoided.

Installation of *Straw Mulch* will include:

- Selection of weed and seed free material
- Good, advance soil preparation
- Appropriate broadcast method, to ensure uniform distribution of long strands and avoid fugitive material
- Determining the correct application rate for the site conditions/characteristics
- Proper crimping to a significant depth, along the grade contour

Inspection and maintenance procedures will verify the material remains intact, is uniform and continues to function as a soil stabilization BMP. *Straw Mulch* (and perhaps seed) will require reapplication if vegetation has not been established and the integrity of the application has been compromised. This will include areas; with little or no coverage, with straw no longer crimped in, with visible signs of surface erosion, paved over with sediment migrations and/or have been damaged by traffic or site activities.

STRAW MULCH (con.)



A good *Straw Mulch* application will ensure evenly distributed, uniform coverage. Crimping must be executed along the grade contour.



Correct application and installation methods should prevent fugitive *Straw Mulch* from migrating off-site.

MATERIALS MANAGEMENT, EQUIPMENT, AND WASTE HANDLING

The MPDES *General Permit for Storm Water Discharges Associated with Construction Activity* requires minimum components be addressed and implemented “to help minimize other non-sediment pollutant contact with storm water runoff.”

Pollutants of concern at construction sites are construction materials, fuels, oil, construction materials, wastes from demolition activities, worker trash and remnants from construction. Managing these wastes and materials properly is necessary to ensure they do not reach state surface waters through storm water runoff.

Materials

The nature of the construction activity will dictate the type of materials that may be brought onto a project as part of the construction activity. Paints, fuels, concrete, cleaning agents and other chemicals are some examples of potential pollution sources that require management.

Equipment

Every permitted construction activity will have some sort of equipment used on-site. Since the permit is issued based on an earth disturbing activity, there will be some sort of grading equipment to create that disturbance, along with company and/or personal vehicles. They will all have the potential for various fluid leaks.

Wastes

The nature of the construction activity will also determine the types of liquid and solid waste generated onsite. At a minimum, most construction sites are likely to have sanitary waste units, remnants from construction, liquid waste wash outs and worker trash to manage.

BULK STORAGE



Fuels and other construction materials that can become entrained in run-off and ultimately impact water quality should be in secondary containment or out of the weather.



Good housekeeping practices will help protect water quality and avoid costly clean-ups.

EQUIPMENT MANAGEMENT



Semi-stationary equipment like pumps, generators, welders, and compressors all require some form of secondary containment, due to the potential for leaks and equipment failure.



Pumping and dewatering operations are especially sensitive, as the equipment is typically staged near the water source. Note the pump and fuel can on the trash rack.

EQUIPMENT MANAGEMENT (con.)



Leaking and poorly maintained equipment should be removed from the site or repaired. Drip pans can serve as an interim control.



Fueling operations need to be executed with care, to prevent spills and cleanup. Spills should be promptly addressed.

SPILL PREVENTION AND RESPONSE

Leaks and spills are common occurrences on construction sites. Procedures and site protocols need to be established that focus on prevention first and then response measures. Personnel training and appropriate response materials standing-by are critically important for any successful spill prevention and response program.



Spill prevention measures will focus on minimizing the potential for a spill. In the event a spill does occur, written response measures should be well communicated, to trigger the appropriate procedures. On-site personnel should be able to readily identify a major spill versus an incidental spill they can respond to.



WASTE MANAGEMENT



Good housekeeping practices will ensure a construction site that is easy to manage and promotes worker safety.



Poor waste management practices create site-wide problems and promote a hazardous work environment.

CONCRETE WASHOUT AREA

Liquid and solid waste from concrete operations is a significant pollutant source with the high pH and array of chemicals it contains. Concrete washouts and slurry cannot be wasted to the ground without containment. A designated, functional *Concrete Washout Area* needs to be constructed and maintained in a fully functional condition to appropriately manage liquid wastes generated from concrete operations.

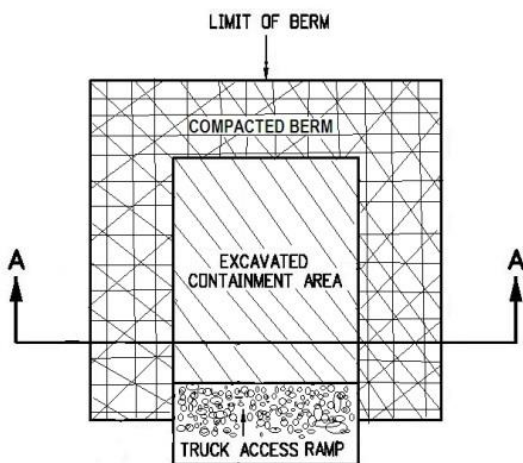

PLAN VIEW

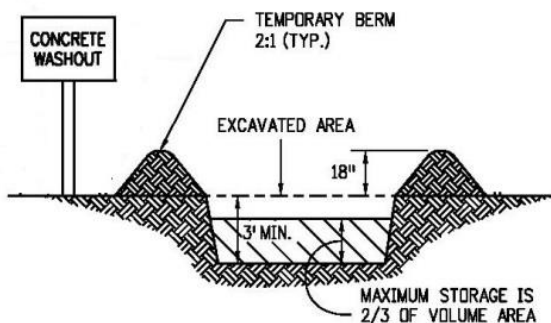

SECTION A

Adapted from Colorado DOT M-Standards

CONCRETE WASHOUT AREA (con.)



Concrete Washout Areas should facilitate vehicular access and fully contain concrete wastes.



Concrete Washout Areas need to be maintained in good operating condition or decommissioned. Good maintenance will help ensure on-going proper use, prevent failures and loss of containment. When decommissioned, all materials must be removed and disposed of off-site.

SAW CUTTING OPERATIONS

Wet or dry sawing operations generate pollutants that must be managed. Wet saw cutting generates slurry and dry saw cutting generates particulates that are pollutant sources, and must be cleaned up.



Slurry created from concrete sawing can be greatly reduced by catching it close to source.



Slurry cannot be allowed to get out of the control of the construction site operator.

PORTABLE TOILETS

Portable toilets will probably be installed on virtually every construction site and need to be recognized as potential pollution sources. The BMPs to manage these facilities are largely administrative and should be detailed in the SWPPP. Aside from monitoring and maintenance for these facilities, procedures for managing them will almost exclusively focus on how and where they are sited. These procedures can become standardized policies and implemented in every SWPPP the contractor prepares. These include stationing the units:

- Out of harm's way (away from traffic zones)
- On level, disturbed ground (not impervious surfaces)
- Away from inlets and curb flowlines
- Adequately secured down



These portable toilets are stationed in a designated staging area.

In the event a toilet does tip, it is easier to respond to it on disturbed ground, as opposed to a paved section. Note the blue biocide discharging down the curb flowline.



CONTACT INFORMATION

MTDEQ Water Protection Bureau

<http://deq.mt.gov/Permits.mcp#waterprotection>
(406) 444-3080

MTDEQ Construction Permit Information

Storm Water - (406) 444-5349

Dewatering - (406) 444-3927

MTDEQ Spill Reporting

(406) 444-0379

MTDES (Disaster and Emergency Services)

(406) 431-0411

MDT's Environmental Services Bureau

(406) 444-7228

US Army Corps of Engineers

Helena – (406) 441-1375

Billings - (406) 657-5910

EPA Region 8 – Montana Operations Office

Helena - (406) 457-5025

Montana Contractors' Association

Helena – (406) 442-4162



Revised April 2014